

Top View

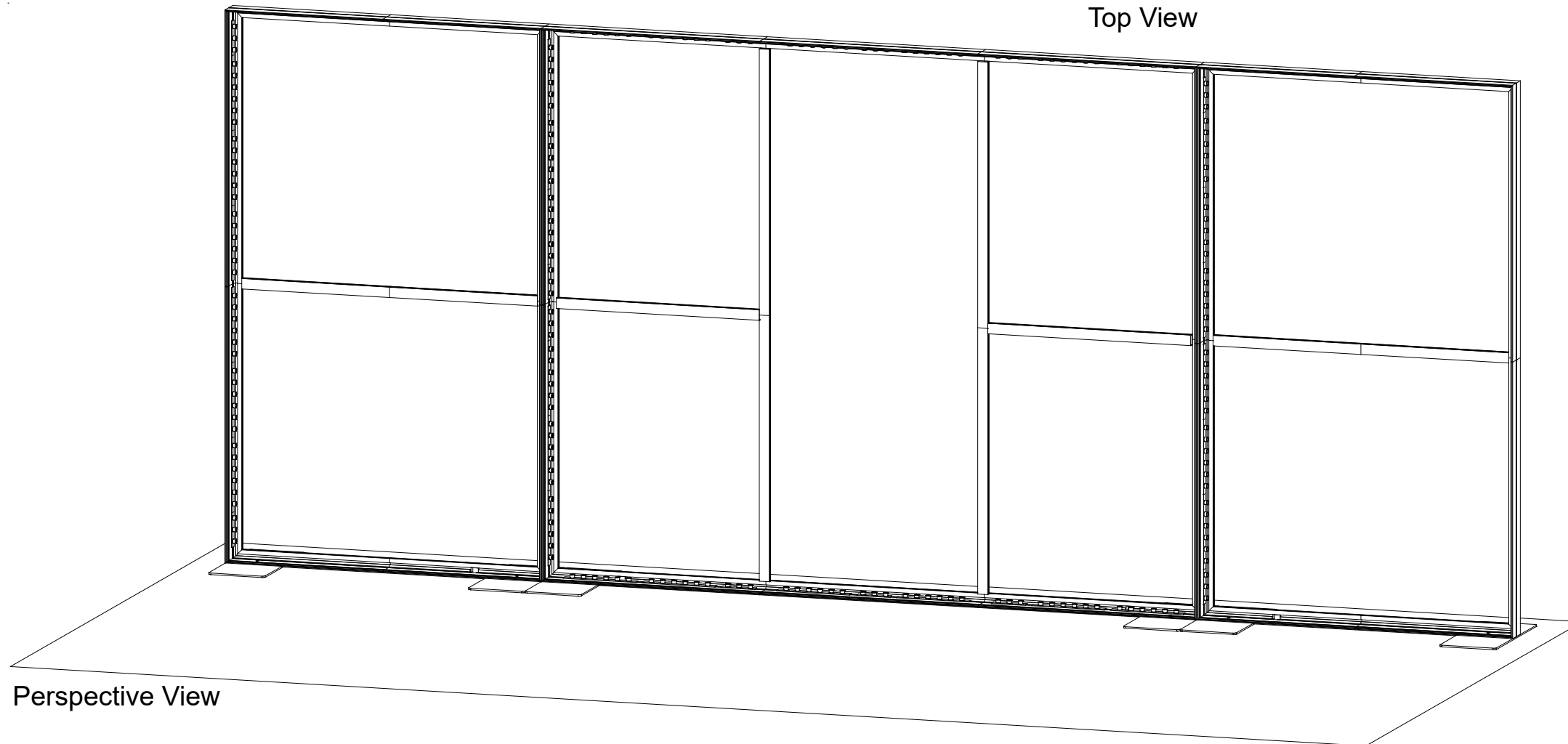

Perspective View

## General Setup Instructions

- Read entire setup instruction manual prior to unpacking parts and pieces.
- The setup instructions are created specifically for this configuration.
- Setup instructions are laid out sequentially in steps, including exploded views with detailed explanation for assembly.

## Cleaning & Packing

- For Cleaning Metal, Plex, & Laminate Parts: Use a **MILD NON-ABRASIVE** cleanser and soft cloth/paper towel to clean all surfaces.
- Keep exhibit components away from heat and prolonged sun exposure. **Heat and UV exposure will warp and fade components.**
- Retain all provided Packing Materials. All provided packing materials are for ease of repacking & component protection.

## Disassembly

- For loss prevention, tighten all set screws and locks during disassembly.

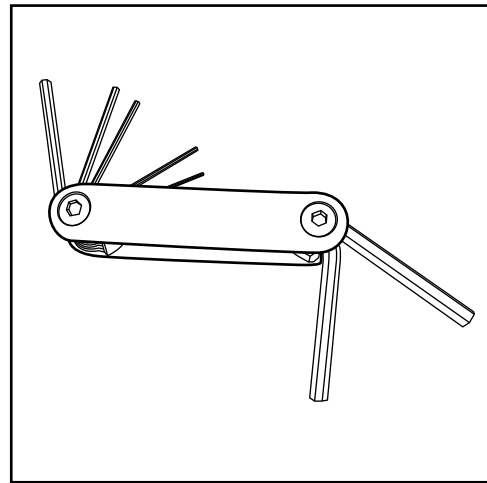

Hex Tool - Essential for Assembly

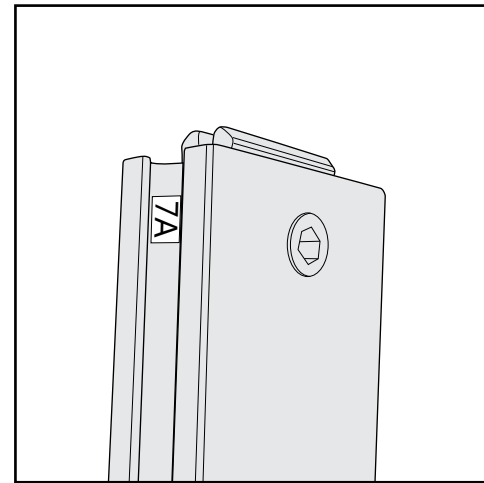

Part Identification - Numbering

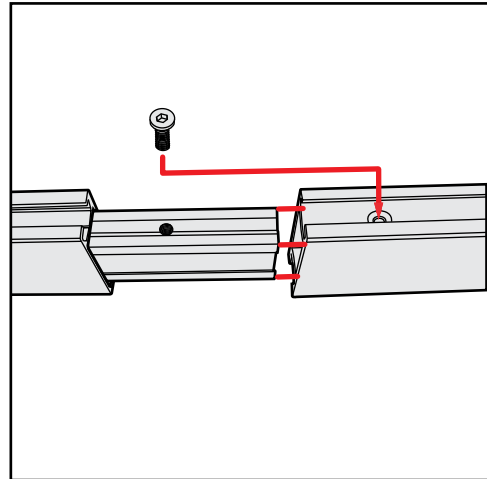

Spline Connection

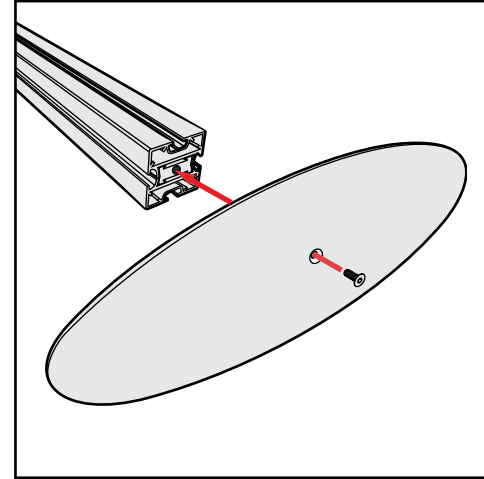

Base Plate & Extrusion Connection

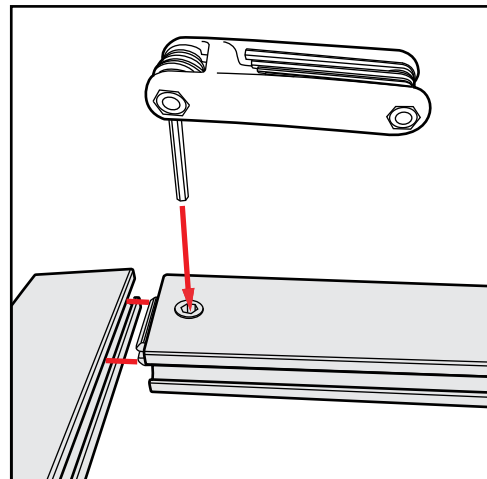

Extrusion & Lock Connection

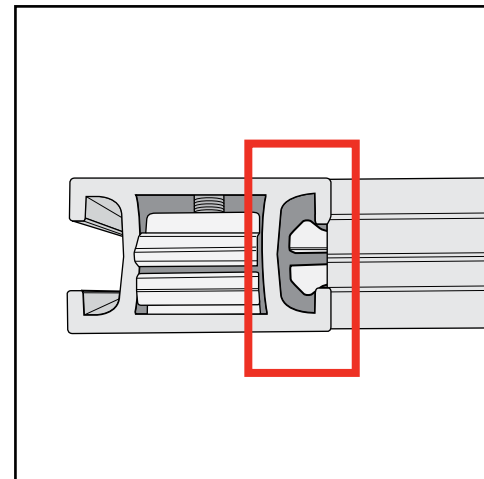

Engaged Lock



**WARNING**



DO NOT USE POWER TOOLS



LADDERS OR LIFTS  
MAY BE REQUIRED



ALL CONNECTIONS MUST  
BE TIGHTLY SECURED

- 1) Locate channels along the edges of extrusions
- 2) Insert graphic corners first into channels then center point of graphic into channels. Allows for proportional fit around the perimeter of the extrusion.
- 3) Working from center to corner, slide silicon edge on graphic into channel.
- 4) After all edges of graphic have been inserted into channels, step back and assess graphic fit, make adjustments where needed.

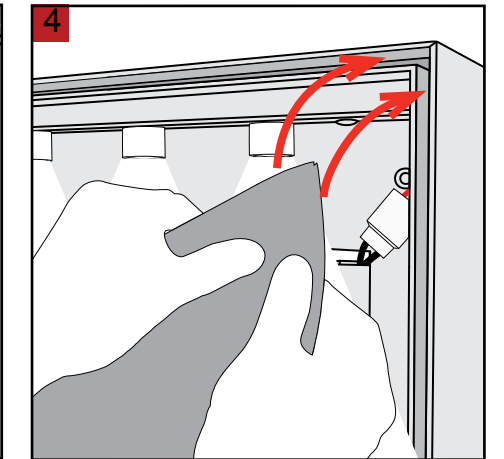
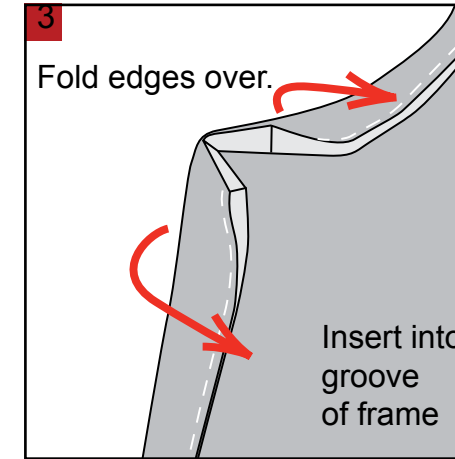
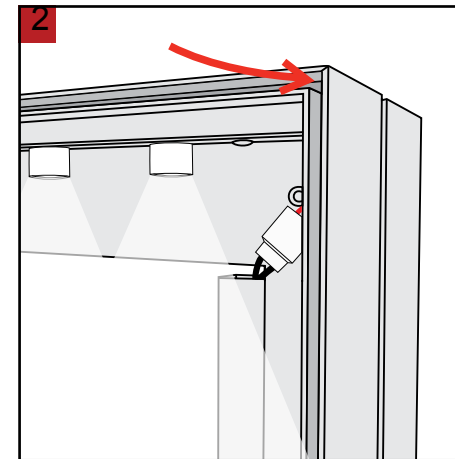
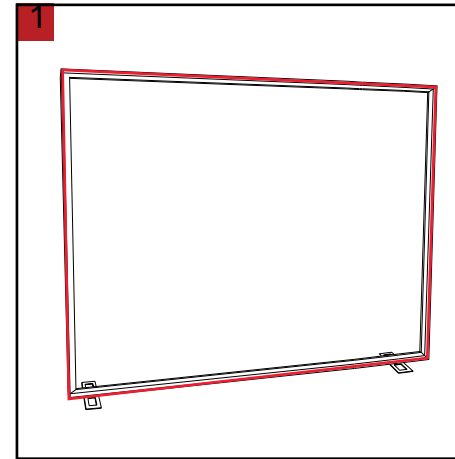

## Straight Connection

When assembling frame, first attach all **straight connectors**, then attach **corner connectors**.

- 1) Place extrusions end-to-end.
- 2) Loosen all knobs, then slide **straight connectors** across the seam of extrusions.
- 3) Tighten all knobs to secure connection.

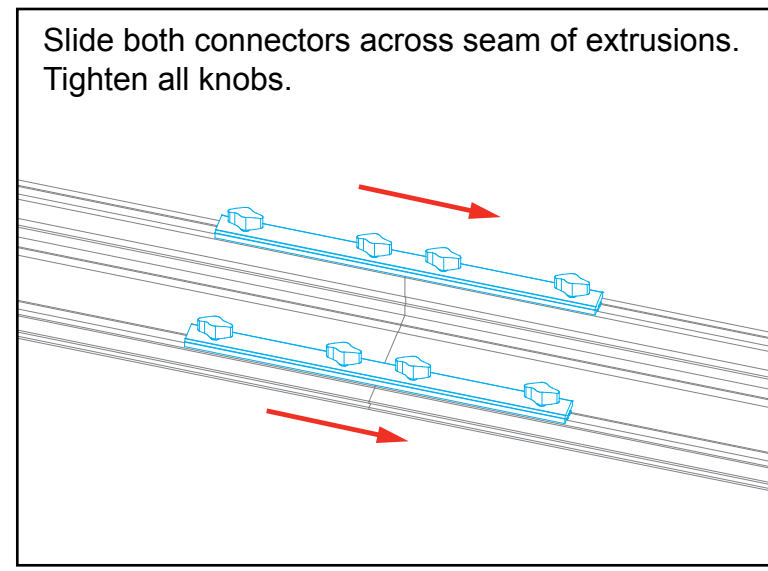
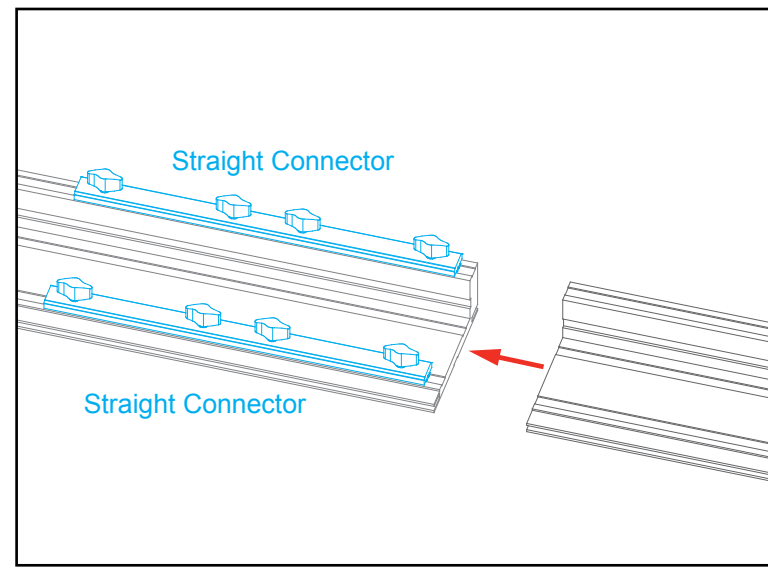

All knobs must be tightened securely to ensure a proper connection.

## Disassembly

- 1) Loosen all knobs.
- 2) Slide connectors off of one extrusion.
- 3) Tighten knobs to prevent loss during packing & shipping.

Keep straight connectors in groove of extrusion. Do not remove connectors during disassembly.

## Corner Connection

- 1) Loosen knobs, then slide vertical extrusions onto **corner connectors** of **lower** horizontal extrusion.
- 2) Slide **corner connectors** of **upper** horizontal extrusion into grooves of vertical extrusions.
- 3) Tighten all knobs to secure connection.

## Disassembly

- 1) Loosen knobs on vertical extrusions.
- 2) Slide the vertical extrusions off of **corner connectors** on lower and upper horizontal extrusions.

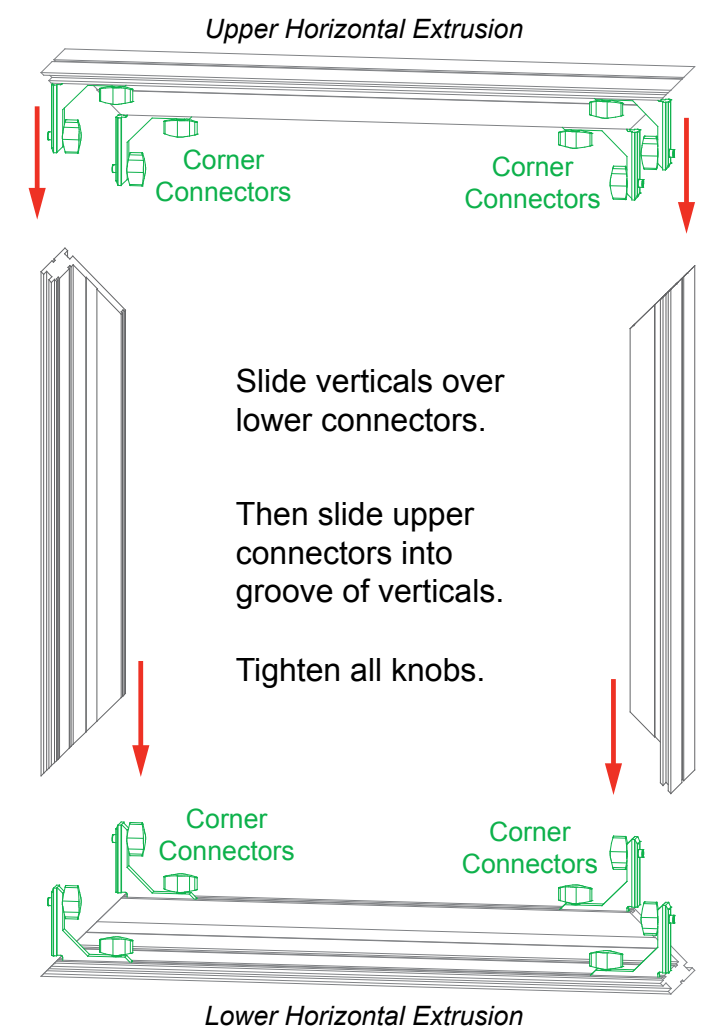

Adjust connectors if necessary to prevent gaps in connection.

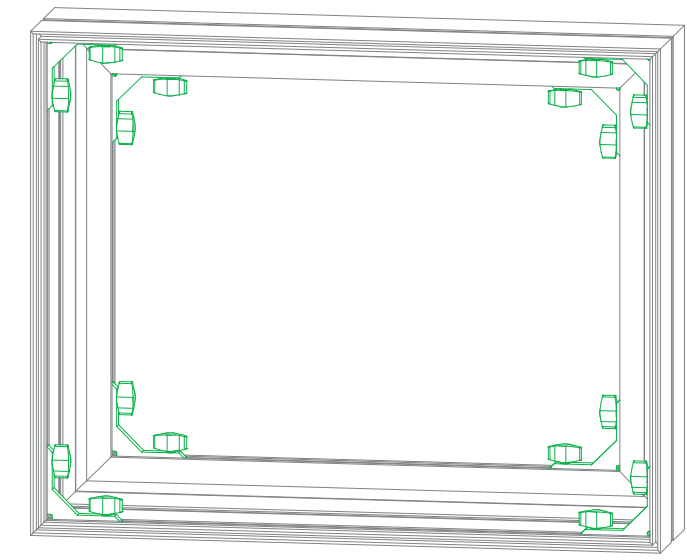

COMPLETED ASSEMBLY

All knobs must be tightened securely to ensure a proper connection.

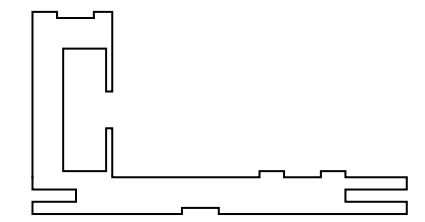

CEI110 Profile

### Top View of Each Level

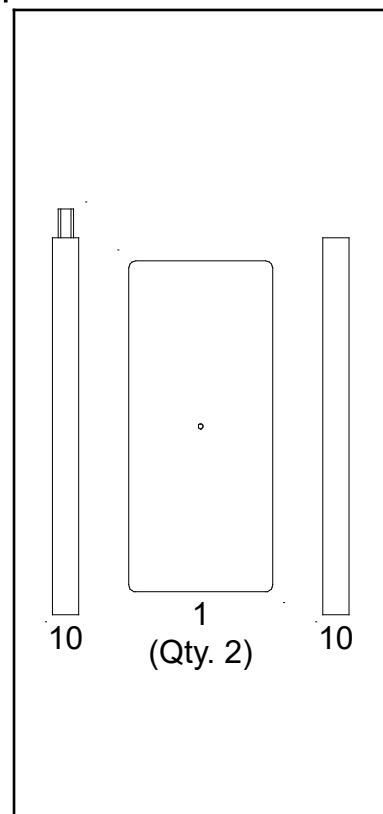

Level 1 (Bottom Level)

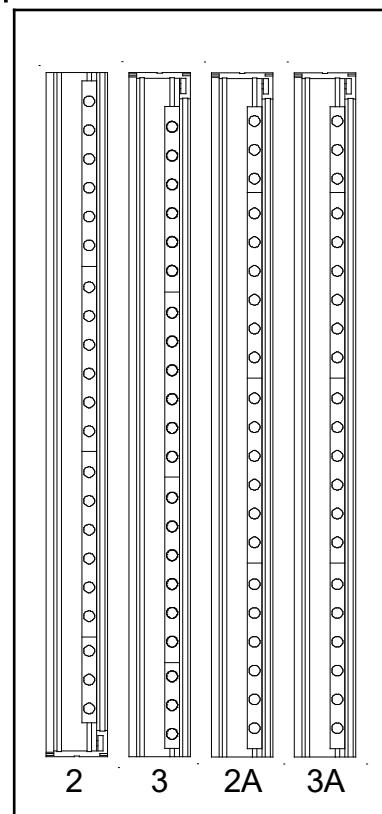

Level 2

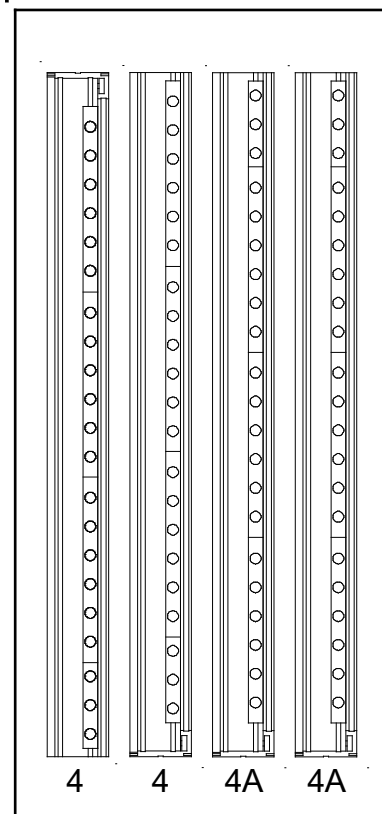

Level 3

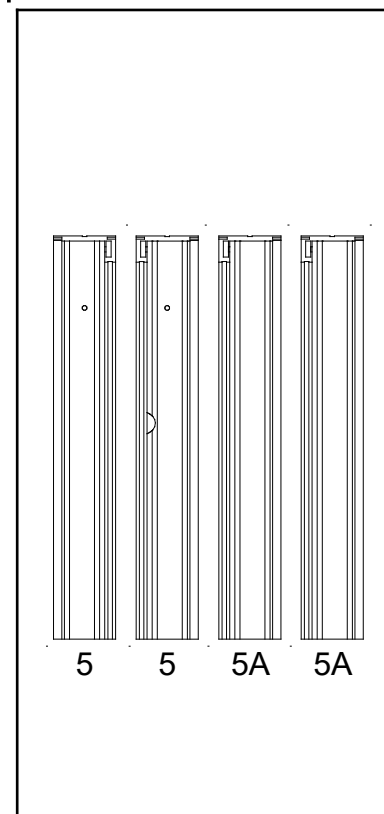

Level 4

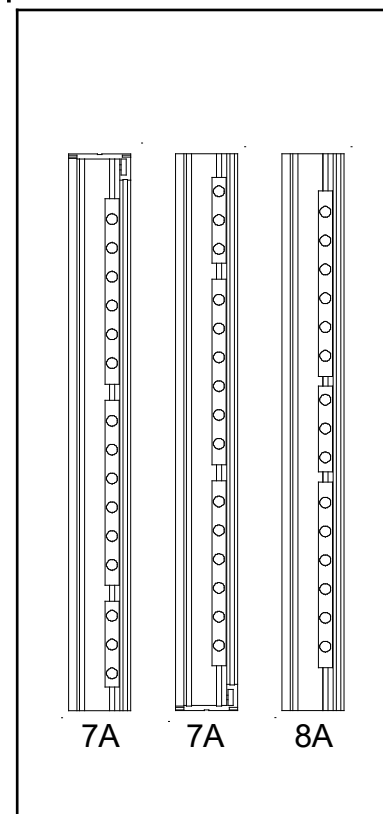

Level 5

Setup Hardware

Setup Hardware

### Top View of Each Level

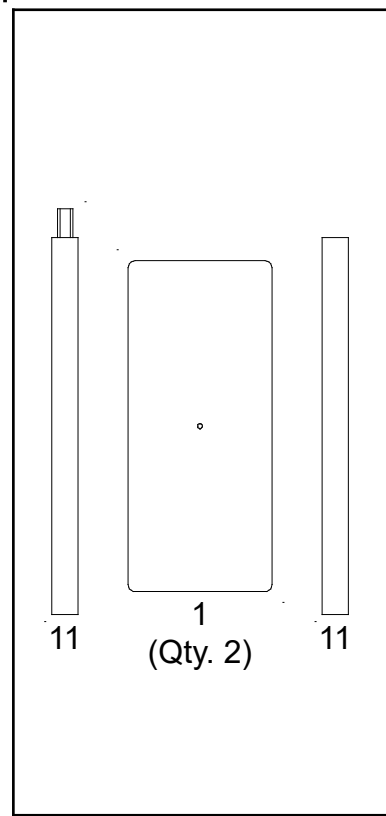

Level 1 (Bottom Level)

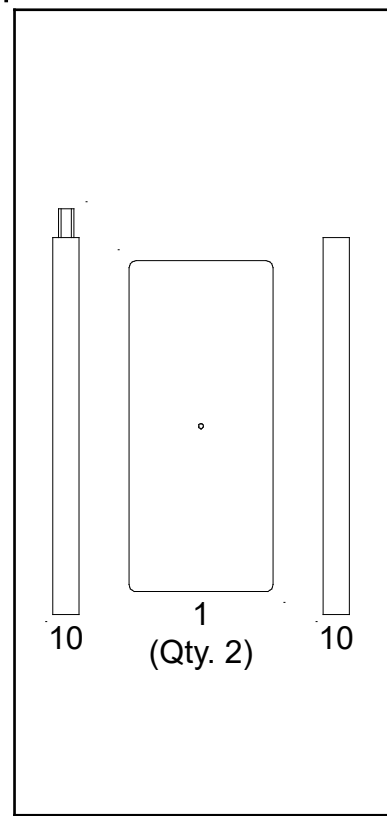

Level 2

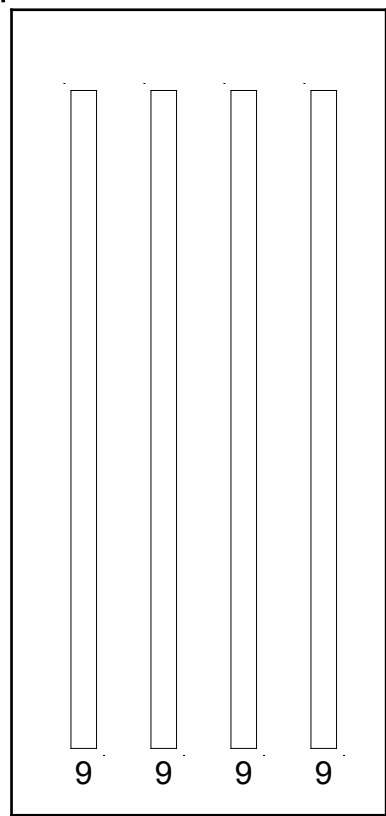

Level 3

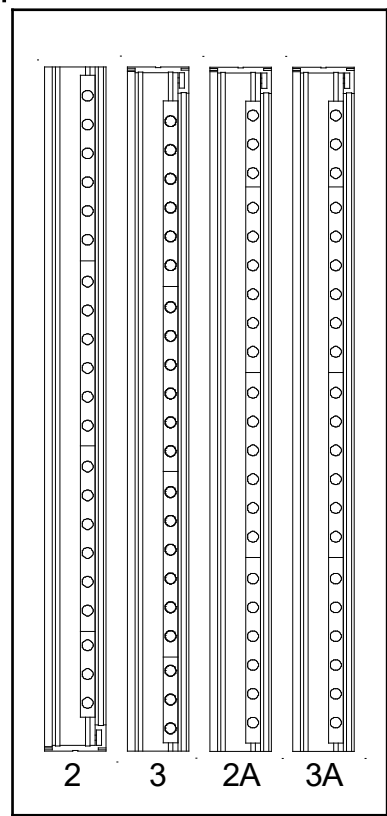

Level 4

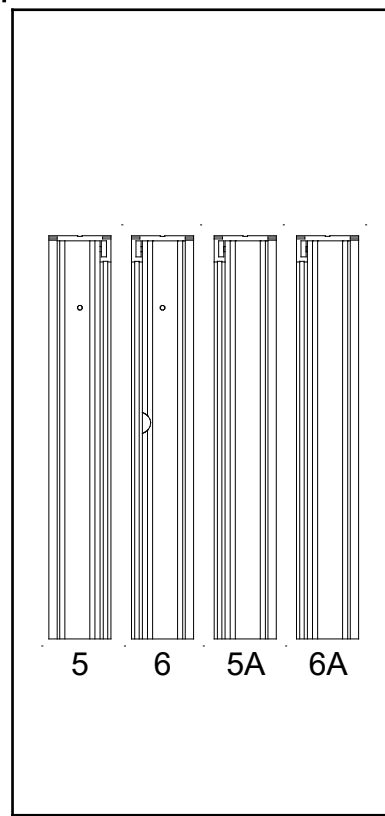

Level 5

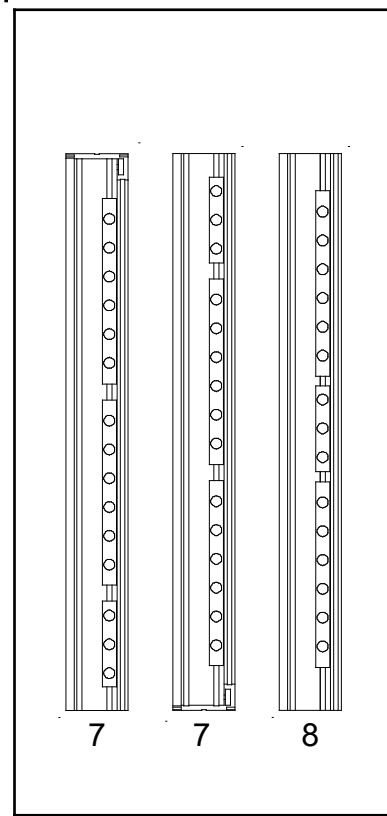

Level 6



Graphics



Graphics

**Steps:**

- 1) Assemble CEI110 extrusions together, as shown, flat on floor. See CEI110 Frame Assembly sheet for details.
- 2) Attach verticals [9] into assembled frame as shown. See **PR53 Connector** and **Z45 Attachment** details.
- 3) Attach horizontals [10] and [11] to assembled frames as shown. See **Z45 Attachment** detail.
- 4) Attach base plates [1] to horizontals [5] [6] and [7], in direction of arrows, using bolts, washers, and wing nuts.
- 5) Install SEG graphic to front and back of assembled frames. See SEG Graphic Installation sheet for details.

Item	Qty.	Description
1	6	Base Plate
2,2A	2,2	47.5" CEI110 Vertical Extrusion
3,3A	2,2	47.5" CEI110 Vertical Extrusion
4,4A	2,2	47.5" CEI110 Vertical Extrusion
5,5A	2,2	28" CEI110 Horizontal Extrusion
6,6A	2,2	28" CEI110 Horizontal Extrusion
7,7A	2,2	38.667" CEI110 Horizontal Extrusion
8,8A	1,1	38.667" CEI110 Horizontal Extrusion
9	4	45.677" Z45 Vertical Extrusion
10	4	25.28" Z45 Horizontal Extrusion
11	2	35.94" Z45 Horizontal Extrusion

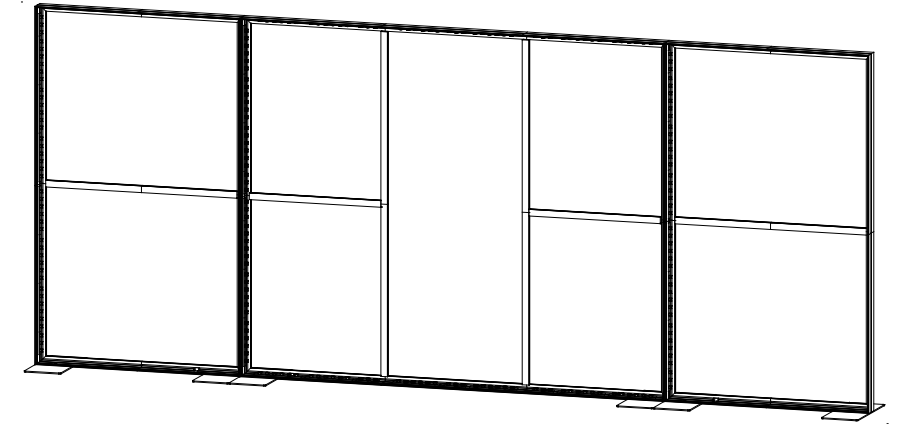

Completed Assembly

**\* PR53 Connector**

Extrusion

PR53 Connector

Set Screw

Slide extrusion over PR53 connector then tighten set screws to secure.

*Note: To prevent product loss, keep all screws attached to connector after disassembling.*

**\* Z45 Attachment**

CEI-110

Z45

Attach Z45 horizontal to back groove of CEI-110 vertical.

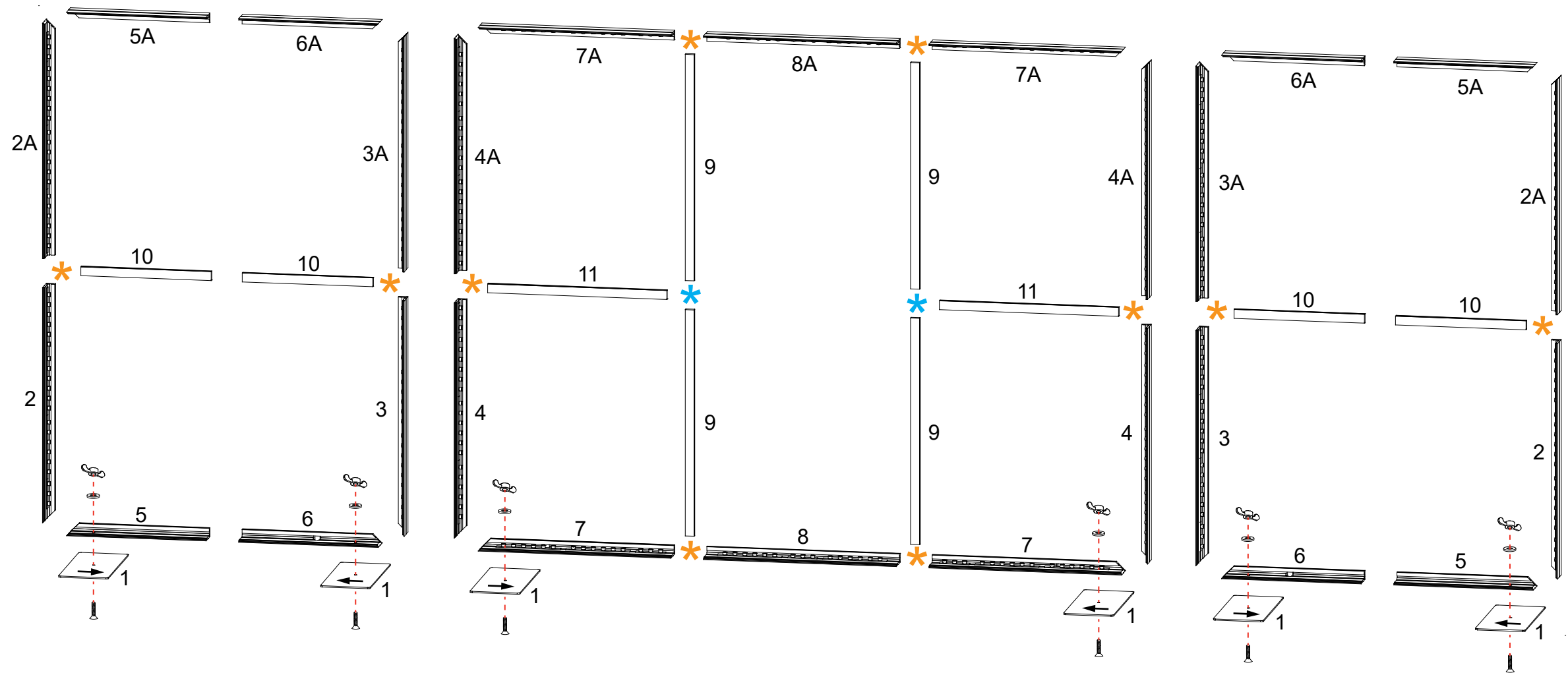

Steps:

- 1) Connect lights and transformers. See [Light to Light Connection](#) and [Light to Transformer Connection](#) details.
- 2) Install SEG graphic to front and back of assembled frames. See SEG Installation sheet for details.

